

Light Weight Inboard Slide Schematic

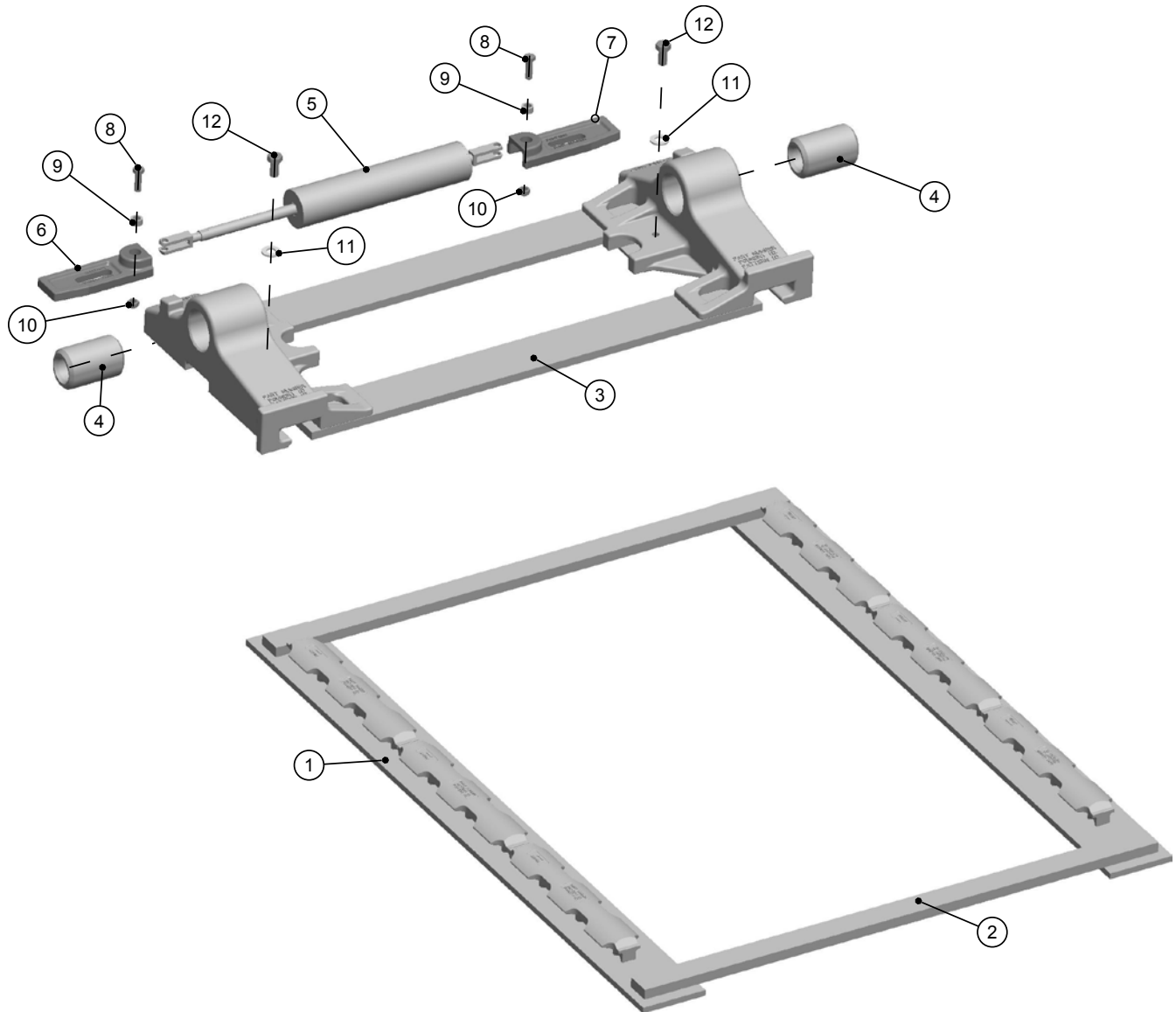

Item	Description	Part No.	Quantity
1	Slide Rail	**	1
2	Rail Stop Bar	*	2
3	Slide Bracket	See Slide Bracket Chart	1
4	Bracket Bushing	BSH-3000*	2
5	Air Cylinder	*	1
6	Locking Wedge, Left	*	1
7	Locking Wedge, Right	*	1
8	Hex Bolt, 3/8-16 x 1.25"	*	2
9	Spacer Bushing	*	2
10	Lock Nut, 3/8-16	*	2
11	Flat Washer, 1/2"	*	2
12	Hex Head Bolt, 1/2-13 x 1.00	*	2

** Slide Rail not available for separate purchase. Only available in air slide and air bracket combination.