

Fontaine® LWI

Light in weight... strong in performance

50,000 lb vertical load

150,000 lb drawbar pull rating

Rated for on-highway use only, including tankers

- Light-Weight-Inboard slide assembly
- For use with the Ultra NT No-Slack® top plate or the Ultra LT lightweight top plate
- 18 lbs lighter than the LWO outboard mount system
- As light as aluminum fifth wheel slider systems – with the durability and cost-effectiveness of steel construction
- Available in 12", 24", 36" or 48" slide travel with 4" increments
- Mounting heights are 6 ¾", 7 ¾" and 8 ¾"
- System weight savings of 100 lbs or more over competitive products – helps fleets offset heavy emission system components
- Improved fuel economy and low up-charge make the LWI very attractive to weight-sensitive, cost-conscious fleets

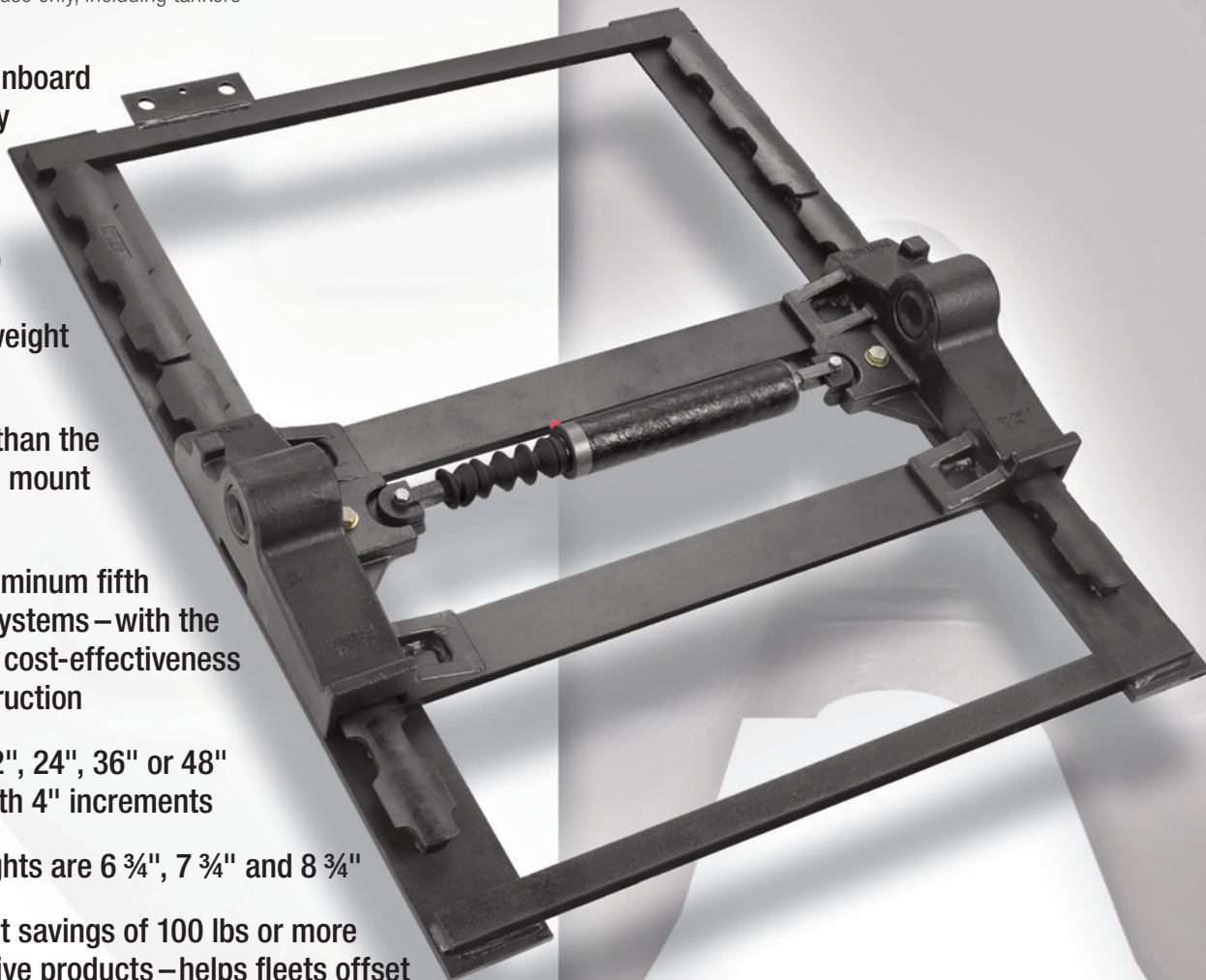

FONTAINE®
FIFTH WHEEL

www.fifthwheel.com • 800-874-9780

Fontaine® LWO

Light in weight... strong in performance

50,000 lb vertical load

150,000 lb drawbar pull rating

Rated for on-highway use only, including tankers

- Light-Weight-Outboard slide assembly
- For use with the Ultra NT No-Slack® top plate or the Ultra LT lightweight top plate
- Up to 50 lbs lighter than competitive outboard slide systems
- As light as aluminum fifth wheel slider systems – with the durability and cost-effectiveness of steel construction
- Available in 12", 16", 24", 36" or 48" slide travel with 4" increments
- Mounting heights are 6 ¾", 7 ¾", 8 ¾" and 9 ¾"
- System weight savings of 80 lbs or more over competitive products – helps fleets offset heavy emission system components
- Improved fuel economy and low up-charge make the LWO very attractive to weight-sensitive, cost-conscious fleets

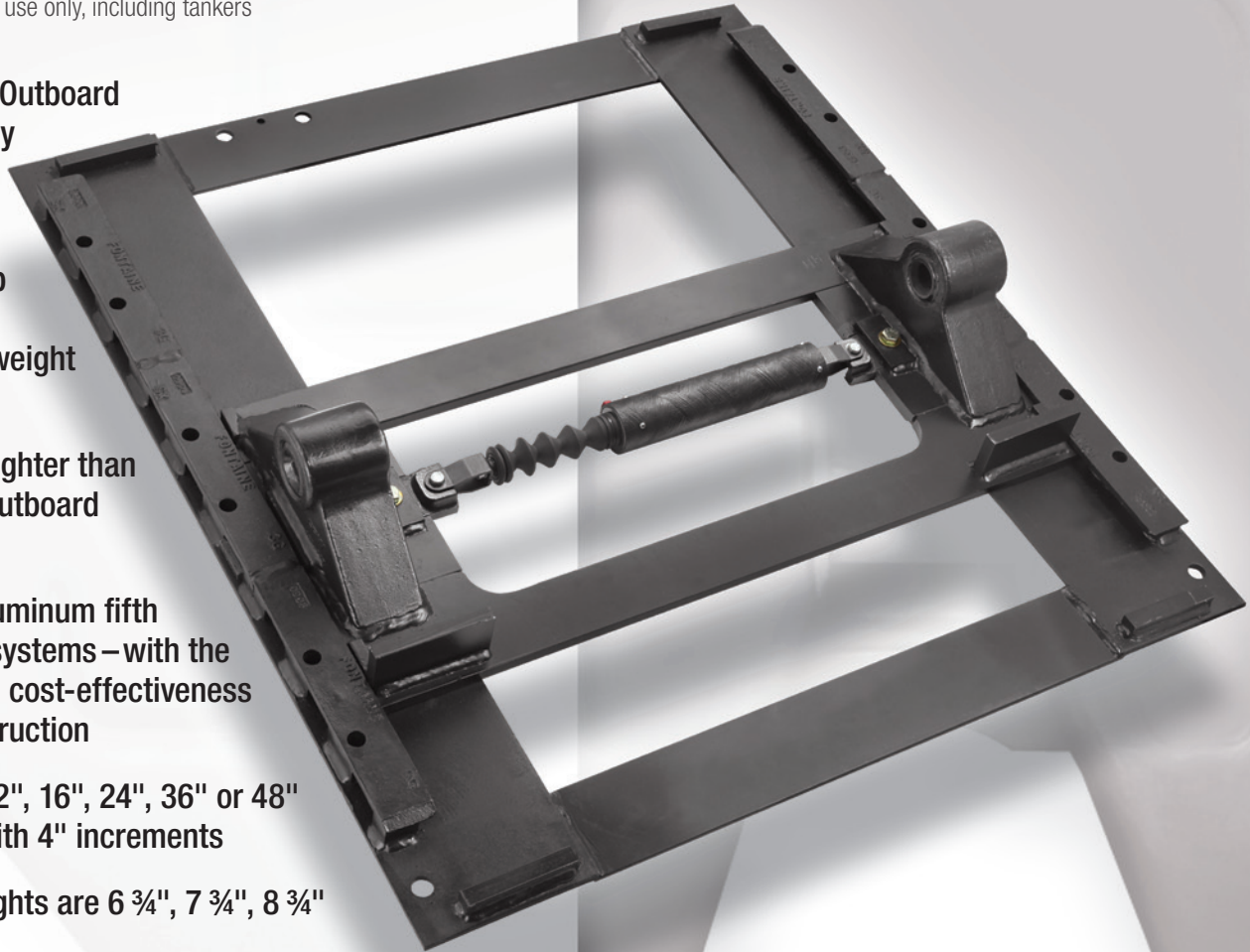

FONTAINE®
FIFTH WHEEL

www.fifthwheel.com • 800-874-9780